

## ZIP 100 Zip-screen Screw-fit side guides



- Ensure that the awning is fixed to a sufficiently secure base. If needed - contact the façade- or window supplier for specific information.
- Check that the Zip-screen fits where supposed to be installed.
- Opening windows and doors may limit the possibility for installing Zip-screens.
- The motor and any control equipment must be installed by an authorised electrician.

## 1 Installing the guide rails

Use the drilled holes in the guide rails to mark the hole positions on the mounting surface (wall A or niche B) and, if necessary, drill to correct diameter.

Screw the guide rails to the surface with suitable screws and check so that the profiles are vertical, parallel and on the same level.

Before continuing, check that the rails are installed with the same c-c as the legs of the cassette gables. Adjust if needed.

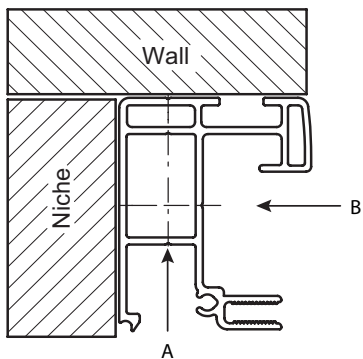

Left guide rail,  
top view

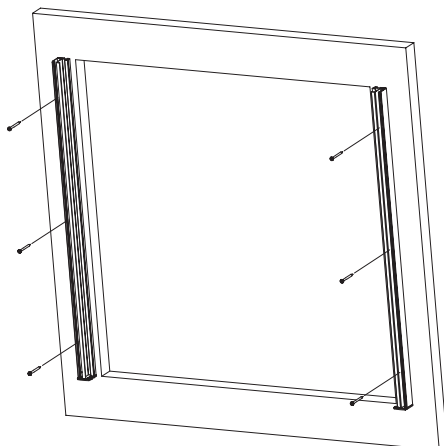

1b Installing extension brackets (optional)

Measure the positions for the extension brackets - then scw these to the wall with proper screws.

Pre-assemble the flange nuts on the T-slotted bolts. Slide these into the guide rails (2 pcs/bracket).

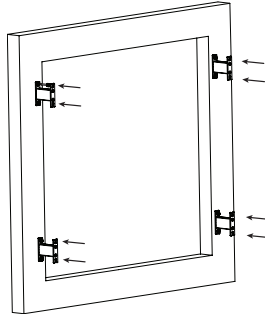

h (mm)	No. brackets/rail
< 1050	2
1051-1800	3
1801-2550	4
2551-3300	5
3301-3500	6

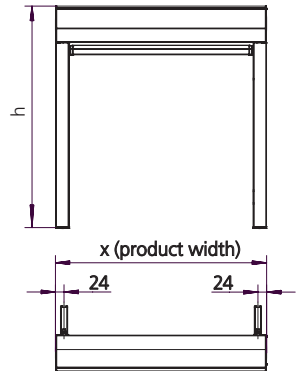

Screw the guide rails to the extension brackets

Make sure the guide rails are vertical, parallel and levelled.

Assemble the cassette according to the manual.

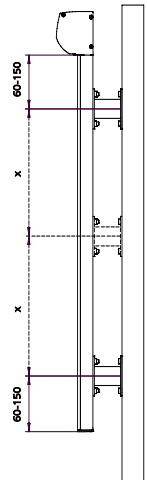
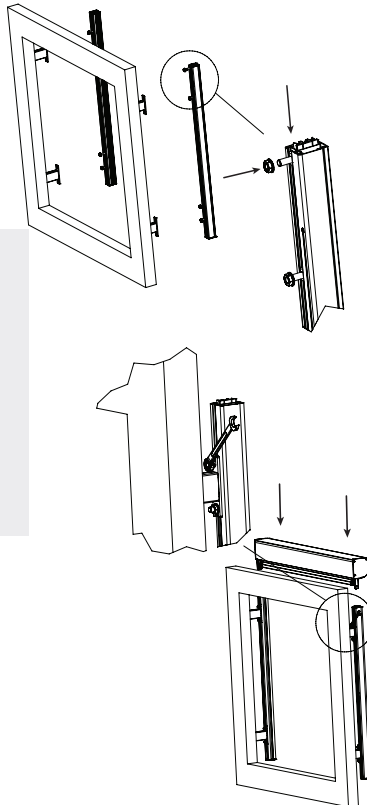

## 2. Assembling the cassette + cassette support (optional)

Lift the cassette on top of the guide rails, make sure not to damage the motor cable.

Carefully assemble the legs of the cassette gables into the guide rails, make sure the cassette gables rest on the guide rails and are levelled.

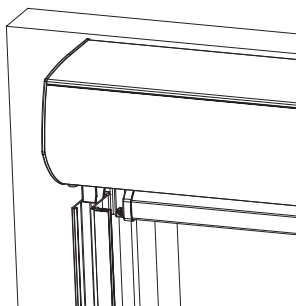
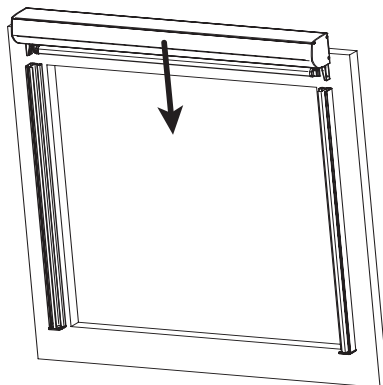

Screw the cassette support (optional) to the wall

Assemble the upper slot on the back side of the cassette on to the cassette support.

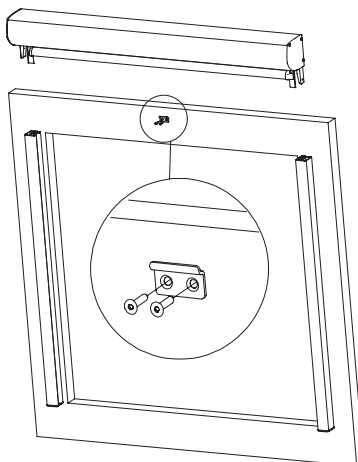
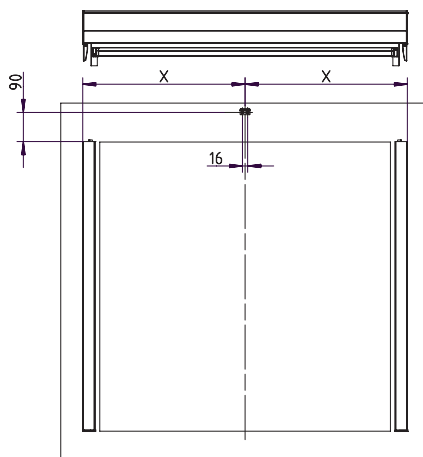

3. Assembling the Zip guides

Assemble the plastic guides for the fabric by sliding them onto the “zipper” on the sides of the fabric/front profile. See below.

Make sure the plastic profiles are fitted correctly in the aluminium profiles. The inner rubber part of the profile must be on the inside of the aluminium groove.

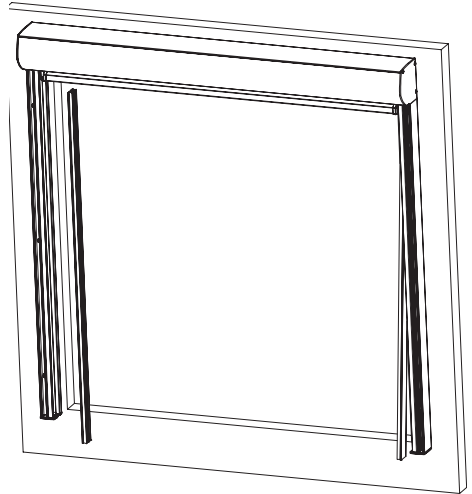

Cut upper end on plastic profile

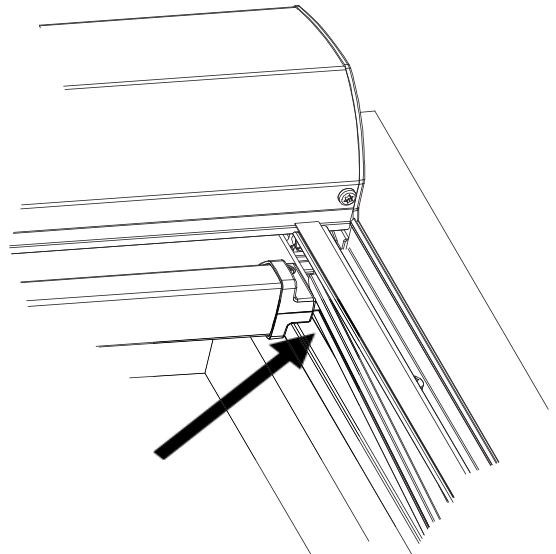
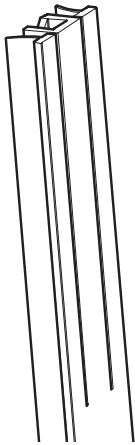

#### 4. Assembling the cover profiles

Finish the installation by assembling the cover profiles on both sides.

Steer in the side of the cover profiles that are facing the window, make sure the plastic profile is not being stuck between the aluminium profiles, and that both alu.profiles and the plastic profiles are aligned at the bottom end cap.

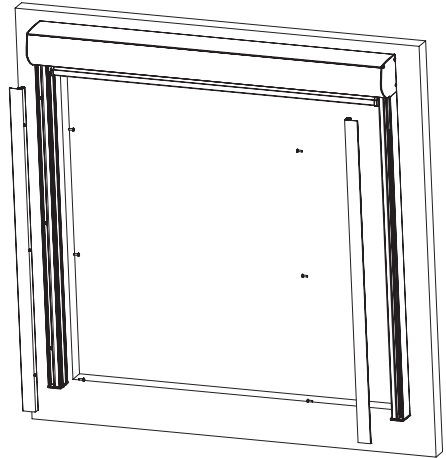

When the cover profiles are in place – gently screw\* the profiles onto the guide profiles using the pre-fabricated holes.

\*Use a screwdriver – do not overtighten.

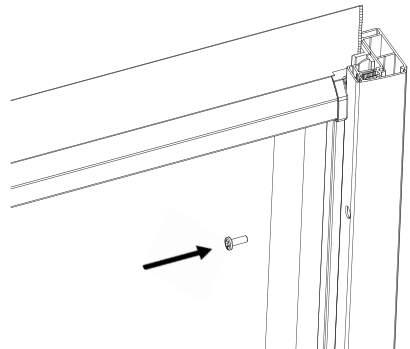

Connect the motor to the electricity.

Run the Zip-screen down + up and check that it operates smoothly.

If needed - program the end positions according to relevant instructions from the motor fabricator.

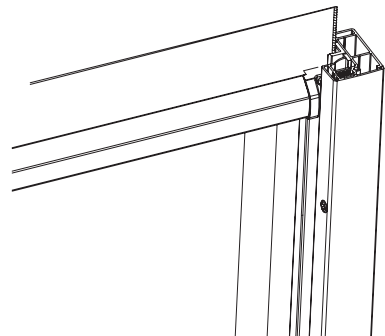

## Maintenance

### **Maintenance:**

The frame and the fabric are subjected to dirt and pollution and should be cleaned at least once a year in order to retain their high finish. This is particularly important in more exposed installations, e.g. environments near the sea. Use a soft cloth, tepid water and a mild cleaner. Do not use a high-pressure washer as it can damage the awning fabric and any electrical equipment, etc. For a detailed description of cleaning the fabric, please refer to its usage instructions.

### **Changing the fabric:**

Before changing the awning fabric it is recommended to contact the company from which the awning was purchased to arrange an inspection of the frame. This company can provide more information about changing the fabric and also provides advice in case some other components may need to be replaced in order for the awning to maintain its finish and function.

### **Warning!**

Always allow a professional to perform work that requires the cassette to be opened. The cassette needs to be opened when replacing the motor and/or fabric. When the cassette is opened, other parts can be damaged or out of position, and moving parts become accessible.

Any work with the motor requires proper authorization. This should therefore always be carried out by a professional.

*The original document may not be altered in text or version without the consent of Hunter Douglas Scandinavia*